



FML Series Lens for the Cree XLamp¹ LEDs

- High efficiency
- Available in five different beam profiles
- High homogeneity of the light beam
- Patent pending
- Designed for use with Cree XLamp¹ LEDs
(please contact Fraen for suitability of this lens with other LEDs)

The FML series lenses offer highly efficient solutions delivered in a compact size.

The design of the FML series insures that almost all of the light emitted by the LED is captured and usefully directed, resulting in a lens with maximum performance and efficiency.

A software-optimized aspheric profile enables the generation of several different beam output patterns: narrow, medium, wide, elliptical and flood profiles².

Typical applications are:

- General indoor lighting
- Portable lighting
- Commercial lighting
- Architectural lighting
- Retrofit lighting



1. Cree® XLamp is a trademark of Cree, Inc. For technical information about these LEDs, please refer to the Cree® XLamp datasheet or visit: www.cree.com.
2. Typical beam divergence may change with color temperature and binning.

FRAEN Corporation OMG	FRAEN Corporation Srl
80 Newcrossing Road	Via delle Querce, 26
Reading MA 01867	27020 Trivolzio (PV)
USA	Italy
Phone: +1 781.205.5300	Phone: +39 0382 1933.1
Fax: +1 781.942.2426	Fax: +39 0382 1933.239

Inquiries: optics@fraen.com
Website: FraenOMG.com

For ordering or sales information in your region, please contact one of our offices listed above or visit www.FraenOMG.com/Contact.



General Characteristics

Materials

Lens Material	Optical Grade PMMA
Holder Material	ABS/PC - Black
Operating Temperature range	-40° C / + 80° C
Storage Temperature range	-40° C / + 80°C

Average transmittance in visible spectrum (400 – 700nm) >90%, as measured using 3mm thick Optical Grade PMMA.

Please note that flow lines and weld lines on the external surfaces of the lenses are acceptable if the optical performance of the lens is within the specification described in the section “OPTICAL CHARACTERISTICS”

IMPORTANT NOTE – Lenses handling and cleaning:

- *Handling: Always use gloves to handle lenses and/or handle the lenses only by the flange. Never touch the outside surfaces of the lenses with fingers; finger oils and contamination will absorb or refract light.*
- *Cleaning: Clean lenses only if necessary. Use only soap and water to clean the surfaces and lenses. Never expose the lenses to solvents such as alcohol, as it will damage the plastic.*

Scope

This datasheet provides information about the FML series lenses for Cree XLamp LEDs.

- FML-N1-R Narrow Beam
- FML-M1-R Medium Beam
- FML-W1-R Wide Beam
- FML-E1-R Elliptical Beam
- FML-F1-R Flood Beam

And lens assemblies (lenses in black holders)

- FML-N1-MLB Narrow Beam
- FML-M1-MLB Medium Beam
- FML-W1-MLB Wide Beam
- FML-E1-MLB Elliptical Beam
- FML-F1-MLB Flood Beam



Optical Characteristics – On-axis Intensity¹, Beam Angle², Field Angle³

LED	Beam Shape	On-axis Intensity (peak)	Beam Angle (FWHM)	Field Angle (FW10%)
MC-E Dynamic White	Narrow	24 cd/lm	7°	15°
	Medium	3.7 cd/lm	26°	40°
	Wide	1.8 cd/lm	39°	57°
	Elliptical	5.2 cd/lm	9° x 40°	23° x 51°
	Flood	<i>Pending</i>	<i>Pending</i>	<i>Pending</i>
XM-L Single Die White	Narrow	19 cd/lm	6°	14°
	Medium	2.5 cd/lm	27°	41°
	Wide	1.3 cd/lm	35°	66°
	Elliptical	4.0 cd/lm	7° x 40°	19° x 51°
	Flood	<i>Pending</i>	<i>Pending</i>	<i>Pending</i>
XM-L EZ White	Narrow	20 cd/lm	8°	17°
	Medium	3.8 cd/lm	26°	40°
	Wide	1.8 cd/lm	39°	58°
	Elliptical	<i>Not approved</i>	<i>Not approved</i>	<i>Not approved</i>
	Flood	<i>Pending</i>	<i>Pending</i>	<i>Pending</i>
XM-L RGBW	Narrow	14 cd/lm	10°	19°
	Medium	2.8 cd/lm	15°	40°
	Wide	1.5 cd/lm	37°	53°
	Elliptical	<i>Not approved</i>	<i>Not approved</i>	<i>Not approved</i>
	Flood	<i>Pending</i>	<i>Pending</i>	<i>Pending</i>

- (1) To calculate the on-axis intensity (cd), multiply the on-axis value, above, of the lens (cd/lm) by the total flux (lm) of the LED used. See “Illumination Calculations” below. Luminous intensity depends on the flux binning and tolerances of the LEDs. Please refer to the LED datasheet for more details on flux binning.
- (2) FWHM is the full angle where the beam intensity is half the on-axis peak intensity
- (3) Field angle is the full angle where the beam intensity is 10% of the on-axis peak intensity



Example Calculations

To calculate intensity (cd): Find the central spot on-axis intensity (cd/lm) for the lens and then multiply this value by the luminous flux (lm) of the LED. Refer to the LED's datasheet for typical flux values; drive current versus flux ratios; color temperature and binning characteristics.

Example intensity calculations:

If a Fraen lens with an on-axis intensity of 21 candela per lumen (cd/lm) is used with an LED that produces 105 lumens of flux, the calculations are as follows:

On-axis intensity = (21 cd/lm) x (105 lumens) = 2205 candela on-axis intensity (one LED).

If 12 LEDs are used in a fixture, then the on-axis intensity = 12 LEDs x 2205 candela/LED = 26460 cd (on-axis – 12 LEDs)

An explanation of illuminance and the effect of distance

One candela at 1-meter distance produces 1 lux. In the above example, the 12 LED fixture produced 26460 candela. If that fixture is illuminating a surface one meter distant, then the *illuminance* on that surface is 26460 lux.

Illuminance decreases with the square of the distance. If you move the fixture so that it is two meters from the surface, then the illuminance falls to 26460 lux/ (2m)² or 6615 lux. Moving the fixture three meters from the surface decreases the illuminance to 26460 lux/(3m)² or 2940 lux.

Beam and Field Angles

Beam and Field Angles are methods of describing the light distribution of a lens. The Beam Angle is expressed as a FWHM value (Full angular Width of the beam where it reaches Half the Maximum intensity). The Field Angle is a similar concept, sometimes expressed as FW10%, and represents the Full Width angle where the beam reaches 10% of maximum intensity.

If the lenses in our example fixture, above, have a Beam Angle of 10° and an on-axis intensity of 26460 cd, then at ± 5° (half of 10°) the intensity will drop to half of 26460 or 13230 cd. If the Field Angle for the fixture is 19°, then at ± 9.5° (half of 19°) the intensity should be 10% of 26460 or 2646 cd.

Most lenses have Beam and Field Angles that are rotationally symmetrical about the center axis of the lens. Lenses with an elliptical beam profile or optics with specifically shaped beam profiles are the exception.

Intensity, illuminance, Beam and Field Angle are all important factors to be considered in a fixture design. Some applications may require specific ratios between the Beam and Field Angle values.

Mechanical Characteristics



Figure 1: Identifying the lenses by their front view

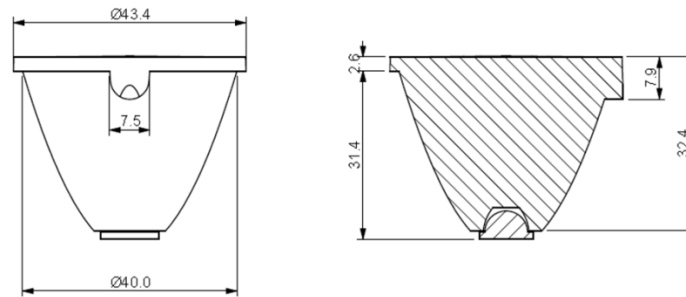

(All dimensions in millimeters, ± 0.2 mm tolerance)

Figure 2: FML-1-R lens front and section views

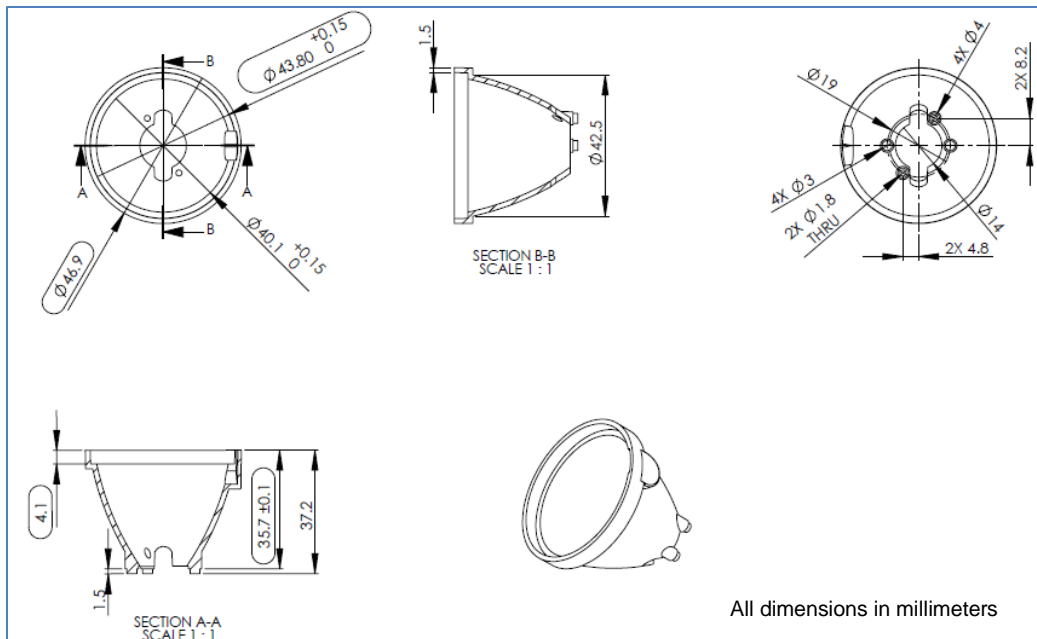
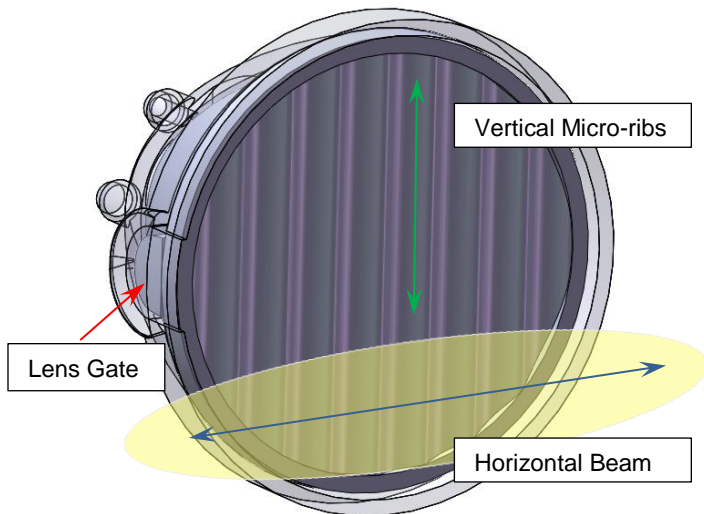

Figure 3: Dimensions and layout features of the FML assembly holder

Please note: The FML holder has legs that are designed to fit into corresponding recesses in the PCB. For proper lens alignment and performance, the holder must be properly seated on the PCB.



The elliptical lens produces a beam with its long axis perpendicular to the micro-ribbing on the lens face.

It is important to note the relationship between the desired beam orientation, lens gate, lens micro-ribbing and the attachment features of the FML assembly when designing your fixture.

Please see Figure 3 for additional layout details

Figure 4: Elliptical beam orientation

Ordering Part Numbers

FML- 1- _ _

R: Lens alone
MLB: Lens in a black holder

N: Narrow beam
M: Medium beam
W: Wide beam
E: Elliptical beam
F: Flood beam

© Copyright 2012 Fraen Corp. All rights reserved.