



## FMT Lens Series for Cree XLamp<sup>1</sup> LEDs

- Small bubble optic for maximum design flexibility
- High light efficiency
- Tape and Reel packaging for automated manufacturing processes
- Includes alignment and glue features for easy assembly
- Mix different beam angles to achieve custom light distributions

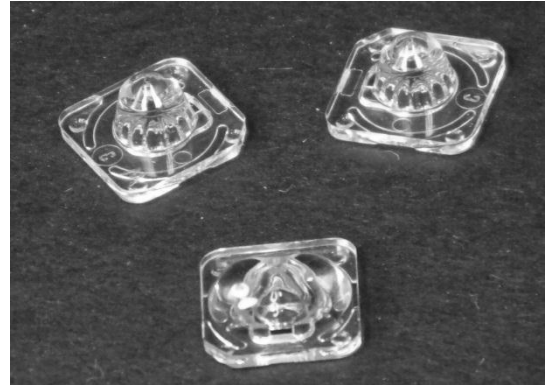
Available in three different beam<sup>2</sup> profiles, the FMT lens series is designed to be compatible with a wide range of Cree XLamp LEDs.

A software-optimized optical profile achieves high collection efficiency, capturing 85% or more of the total flux emitted from the LED.

The lens flange can be glued to the PCB to provide a secure assembly.

Typical applications are:

- Wide area lighting
- Tunnel lighting
- Pedestrian scale road and pathway lighting
- IESNA Type I short illumination (FMT-E1)
- Parking deck lighting
- Low bay lighting
- Fluorescent tube replacements
- Retail, warehouse and 'big box' lighting



- (1) XLamp is a trademark of Cree Corporation. For technical specification on Cree LEDs please refer to the product datasheet or visit [www.cree.com/led-components-and-modules](http://www.cree.com/led-components-and-modules)
- (2) Typical beam divergence may change with LED color temperature and binning.

### FRAEN Corporation

80 Newcrossing Road  
Reading MA 01867  
USA  
Phone: +1 781.205.5300  
Fax: +1 781.942.2426

Inquiries: [optics@fraen.com](mailto:optics@fraen.com)  
Website: [fraen.com](http://fraen.com)

For ordering or sales information in your region, please visit <http://www.fraen.com/optics/contact-us/>.



## General Characteristics

---

### Materials

Lens Material	Optical Grade PMMA
Operating Temperature range	-40° C / + 80° C
Storage Temperature range	-40° C / + 80°C

Average transmittance in visible spectrum (400 – 700nm) >90%, as measured using 3mm thick Optical Grade PMMA.

*Please note that flow lines and weld lines on the external surfaces of the lenses are acceptable if the optical performance of the lens is within the specification described in the section "OPTICAL CHARACTERISTICS"*

### IMPORTANT NOTE – Lens handling and cleaning:

- *Handling: Always use gloves to handle lenses and/or handle the lenses only by the flange surface. Never touch the outside surfaces of the lenses with fingers; finger oils and contamination will absorb or refract light.*
- *Cleaning: Clean lenses only if necessary. Use only soap and water to clean the surfaces. Never expose the lenses to solvents such as alcohol, which can damage the plastic.*

## Scope

---

This datasheet provides information about the FMT lens series.

- FMT-E1-S
- FMT-F1-S
- FMT-W1-S



**Optical Characteristics – On-axis Intensity<sup>3</sup>, Beam Angle<sup>4</sup>, Field Angle<sup>5</sup>**

LED	Beam Shape	Maximum Intensity	Beam Angle (FWHM)	Field Angle (FW10%)
XP-E / XP-E2	Elliptical	0.7 cd/lm (Horizontal) 0.2 cd/lm (Vertical)	118° x 93° (See Figure 1)	134° x 116° (See Figure 1)
	Wide	1.0 cd/lm	29°	81°
	Flood	0.7 cd/lm	34°	102°
XP-G/XP-G2	Elliptical	0.5 cd/lm (Horizontal) 0.2 cd/lm (Vertical)	128° x 100° (See Figure 1)	153° x 128° (See Figure 1)
	Wide	0.7 cd/lm	41°	120°
	Flood	0.5 cd/lm	62°	133°
XQE-HI <sup>6</sup>	Elliptical	0.7 cd/lm (Horizontal) 0.2 cd/lm (Vertical)	124° x 90° (See Figure 1)	140° x 126° (See Figure 1)
	Wide	1.2 cd/lm	28°	77°
	Flood	†	†	†
XT-E <sup>6</sup>	Elliptical	0.5 cd/lm (Horizontal) 0.2 cd/lm (Vertical)	129° x 93° (See Figure 1)	180° x 172° (See Figure 1)
	Wide	.7 cd/lm	39°	168°
	Flood	†	†	†

- (3) To calculate the on-axis intensity (cd), multiply the on-axis value, above, of the lens (cd/lm) by the total flux (lm) of the LED used. See “Example Calculations” below.  
Luminous intensity depends on the flux binning and tolerances of the LEDs. Please refer to the LED datasheet for more details on flux binning.
- (4) FWHM is the full angle where the beam intensity is half the on-axis peak intensity.
- (5) Field angle is the full angle where the beam intensity is 10% of the on-axis peak intensity.
- (6) Data based on optical simulation.
- † Contact Fraen for Flood lens data.

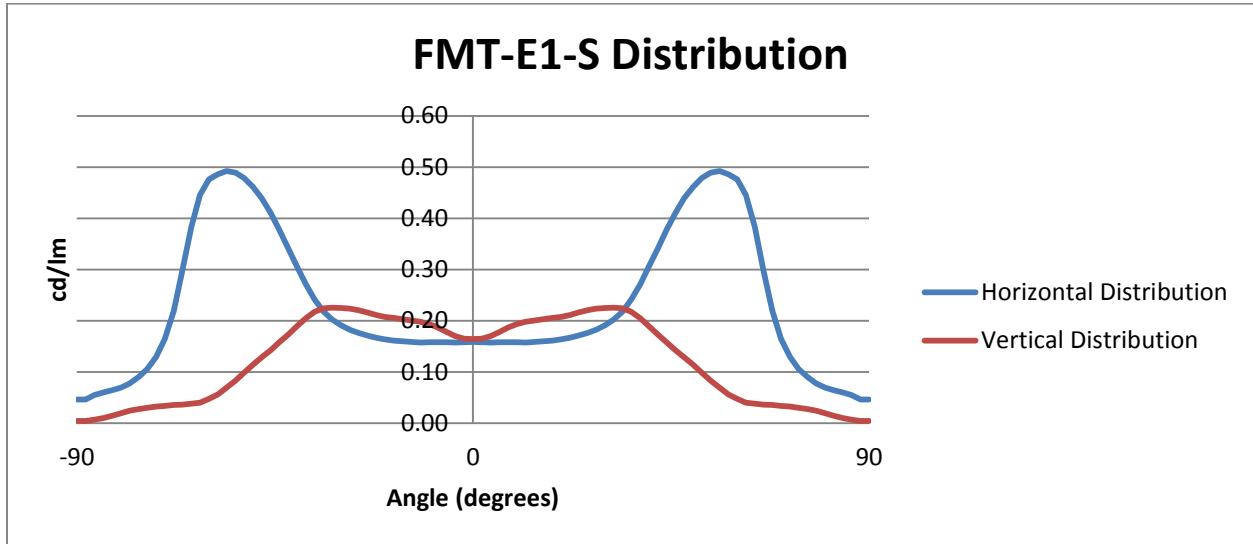


Figure 1: FMT-E1 showing typical horizontal 'batwing' distribution



## Example Calculations

---

To calculate intensity (cd): Find the central spot on-axis intensity (cd/lm) for the lens and then multiply this value by the luminous flux (lm) of the LED. Refer to the LED datasheet for typical flux values, drive current versus flux ratios, and color temperature and binning characteristics.

### Example intensity calculations:

If a Fraen lens with an on-axis intensity of 1.1 candela per lumen (cd/lm) is used with an LED that produces 150 lumens of flux, the calculations are as follows:

On-axis intensity = (1.1 cd/lm) x (150 lumens) = 165 candela on-axis intensity (one LED).

If 12 LEDs are used in a fixture, then the on-axis intensity = 12 LEDs x 165 candela/LED  
= 1980 cd (on-axis – 12 LEDs)

### An explanation of illuminance and the effect of distance

One candela at 1-meter distance produces 1 lux. In the above example, the 12 LED fixture produced 1980 candela. If that fixture is illuminating a surface one meter distant, then the *illuminance* on that surface is 1980 lux.

Illuminance decreases with the square of the distance. If you move the fixture so that it is two meters from the surface, then the illuminance falls to 1980 lux/ (2m)<sup>2</sup> or 495 lux. Moving the fixture three meters from the surface decreases the illuminance to 1980 lux/(3m)<sup>2</sup> or 220 lux.

### Beam and Field Angles

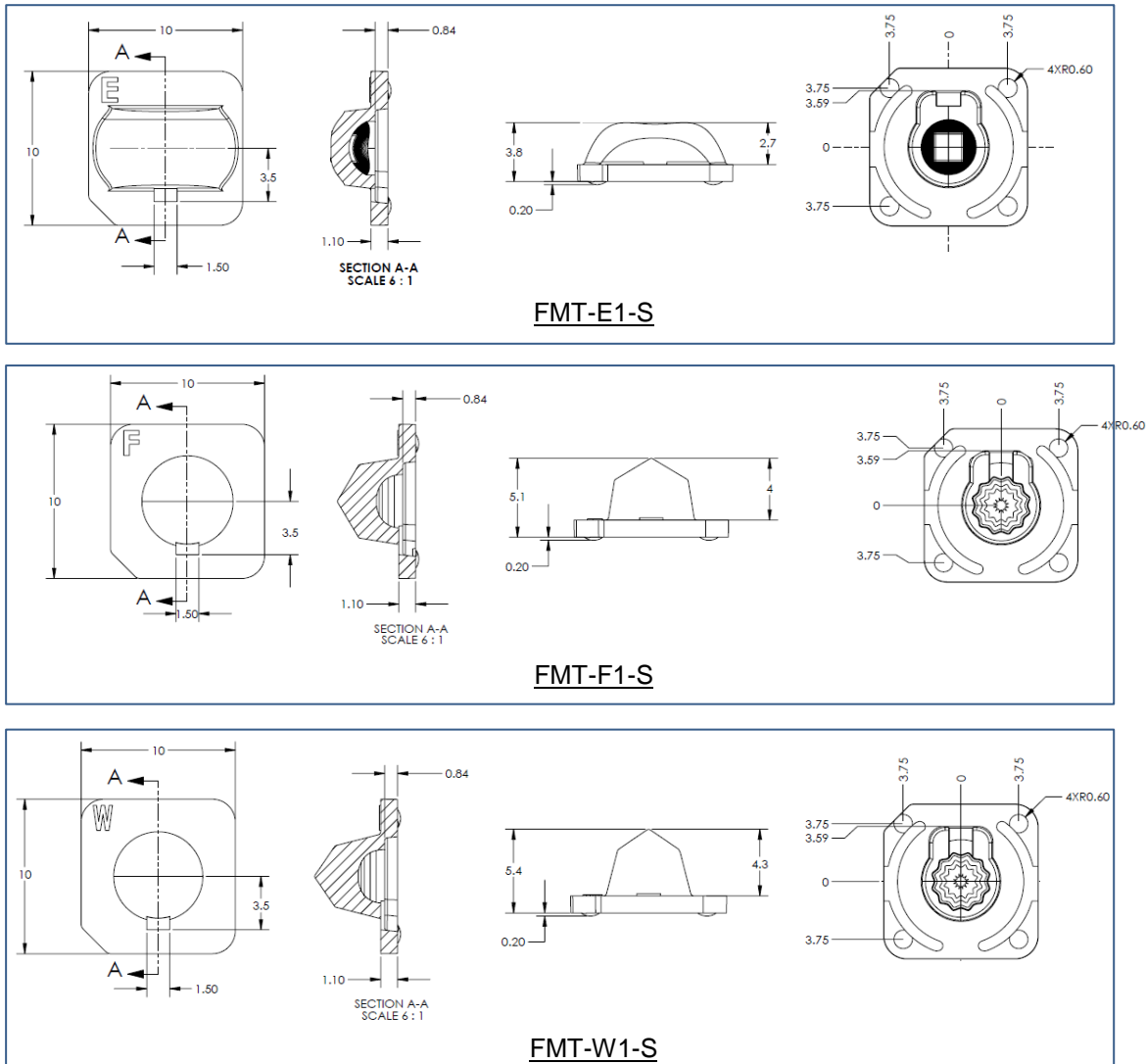
Beam and Field Angles are methods of describing the light distribution of a lens. The Beam Angle is expressed as a FWHM value (Full angular Width of the beam where it reaches Half the Maximum intensity). The Field Angle is a similar concept, sometimes expressed as FW10%, and represents the Full Width angle where the beam reaches 10% of maximum intensity.

If the lenses in our example fixture, above, have a Beam Angle of 29° and an on-axis intensity of 1980 cd, then at ± 14.5° (half of 29°) the intensity will drop to half of 1980 or 990 cd. If the Field Angle for the fixture is 80°, then at ± 40° (half of 80°) the intensity should be 10% of 1980 or 198 cd.

Most lenses have Beam and Field Angles that are rotationally symmetrical about the center axis of the lens. Lenses with an elliptical beam profile or optics with specifically shaped beam profiles are an exception.

Intensity, illuminance, Beam and Field Angle are all important factors to be considered in a fixture design. Some applications may require specific ratios between the Beam and Field Angle values.

## Mechanical Characteristics\*

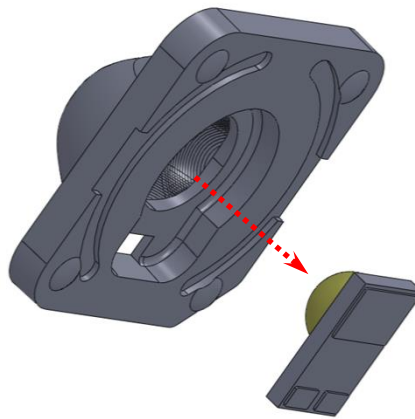


**Figure 2: Mechanical layout of the FMT lenses (all dimensions in millimeters)**

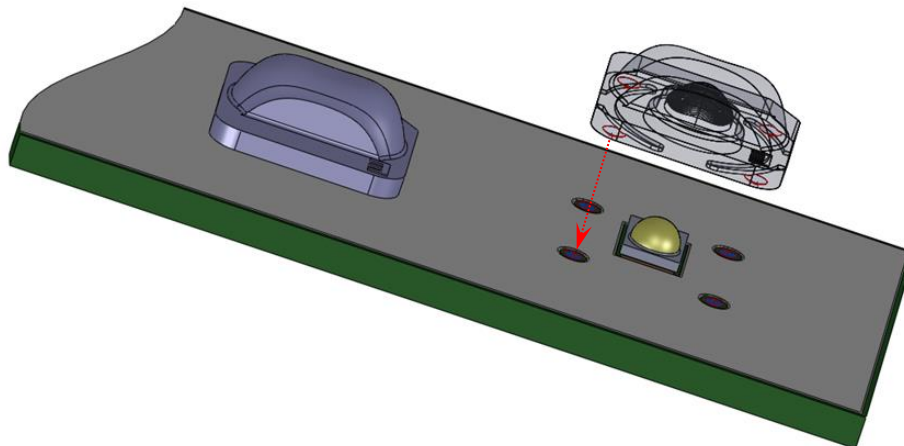
\*Drawings in this datasheet show a rectangular package, dome top LED. The optic can be used with a variety of LED packages. The mechanical mounting and alignment considerations are the same regardless of LED package: the optic should be mounted to the PCB with recesses on the PCB aligning with the bumps on the optic holder flange, and with the LED light emitting surface centered or concentric with the center of the lens. This is the alignment for all data shown in the section titled "OPTICAL CHARACTERISTICS".



**Figure 3:** Note the relationship between the LED package, LED dome and the orientation of the FMT-E1 lens (left). The FMT-E1 lens delivers an asymmetric beam (right) with the wide, batwing profile being aligned with the long axis of the lens.

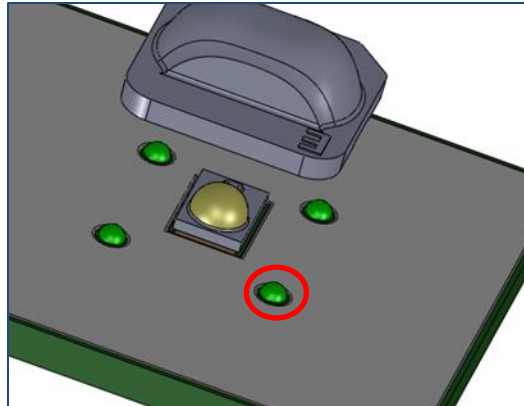


**Figure 4:** The center of the FMT lens should be aligned with the center of the LED light emitting surface.

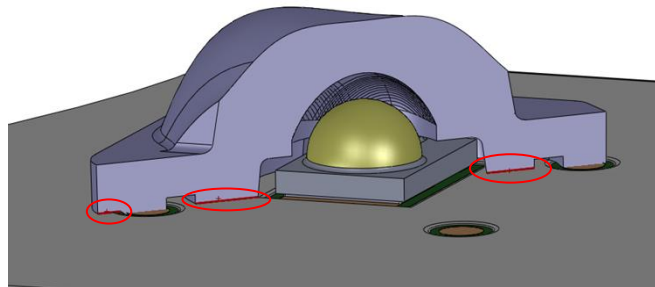


**Figure 5.** The square flange of the FMT lens has 4 bumps, which are designed to fit four corresponding recesses in the PCB solder-mask.

See *Figures 2 and 8* for locating pin layout and dimensions.



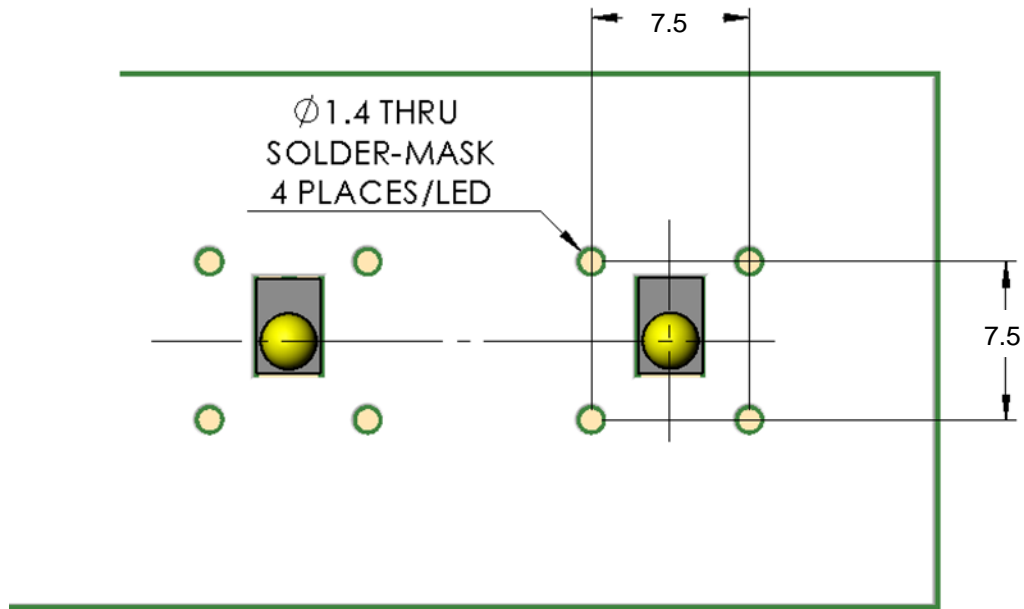
**Figure 6:** A small droplet of glue is placed at each of the 4 solder-mask recess locations, to bond the 4 lens “bumps” to the PCB. A fixture or automated placement machine will be required to assure proper lens location (to center the lens to the LED die).



**Figure 7:** The correct height is achieved when the lens bumps are fully seated in the PCB recesses (same plane as LED solder) and the flat lens bottom contacts the top of the PCB.

DESIGN NOTE: Proper lens to LED alignment requires that the PCB have recesses to accommodate the locating pins on the lens





**Figure 8: Dimensions and layout of the PCB location recesses used to align the lens to the LED. (All dimensions in millimeters)**

## Packaging Information – Tape & Reel

The FMT lens is available only in Tape & Reel packaging. Reel capacity: 515 lenses in pockets with a ten pocket (empty) leader and a five-pocket trailer.

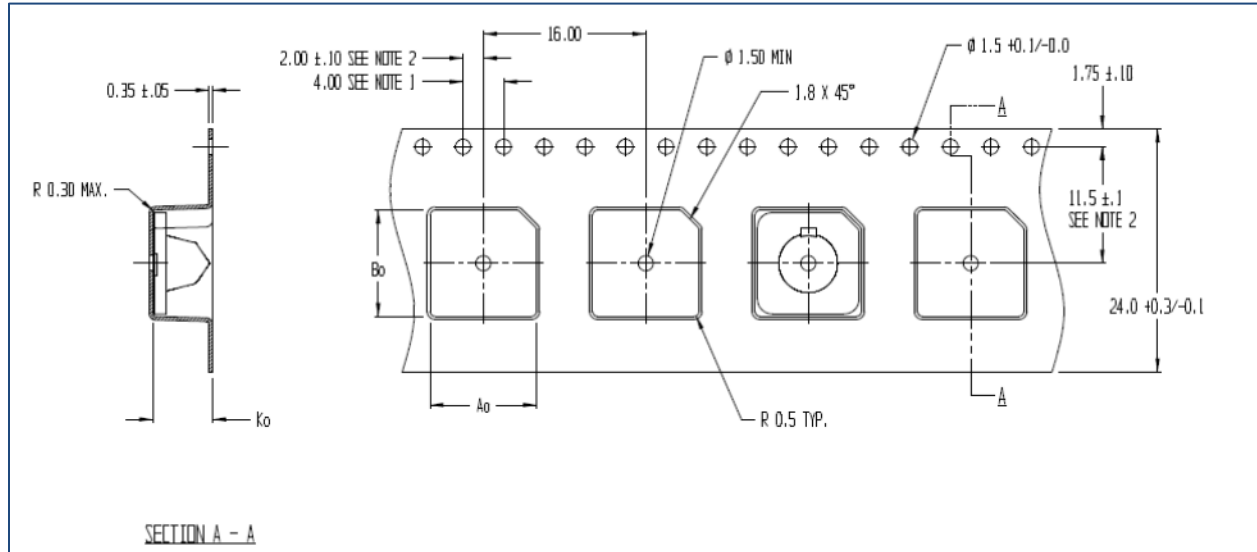


Figure 9: Tape dimensions and layout (All dimensions in millimeters)

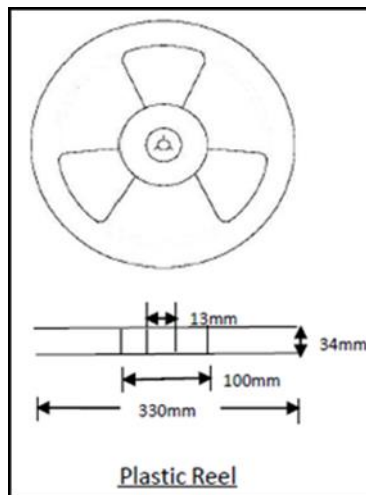


Figure 10: Reel dimensions



## Ordering Part Numbers

---

**FMT-E1-S**  
**FMT-W1-S**  
**FMT-F1-S**

**'Batwing' elliptical lens**  
**Wide lens**  
**Flood lens**

For assistance, please contact Fraen <http://www.fraen.com/optics/contact-us/>.

© Copyright 2016 Fraen Corp. All rights reserved.